



AT100kW/215kWh Outdoor Air Cooled Integrated Energy Storage Cabinet Specification

Contents

Solar Energy Storage All-in-one Cabinet	1
1、 Overview	3
2、 standard	4
3、 System diagram	5
3.1. Topology diagram	5
3.2. Diagram	6
3.3. Dimensional diagram	7
3.4. Product advantages	7
4、 All-in-one cabinet technique	8
4.1. System cabinet parameters	8
4.2 Components Introduction	10
4.2.1 Battery energy storage system	10
4.2.2 Battery Management System(BMS)	11
4.2.3 Electrical system	12
4.2.4 Energy Storage Converter Power Module (PCS)	14
4.2.5 Temperature control system	17
4.2.6 Fire protection system	17
4.2.7 Monitoring system	18
5、 Safety, EMC and lightning protection characteristics	20
6、 Environmental and Reliability Test Requirements	22
7、 Photovoltaic (optional)	23
8、 Main configuration list	24
9、 Packaging, transportation and storage	25
9.1. Packaging	25
9.2. Transportation	25
9.3. Storage	25
10、 revision	25

1、 Overview

This series of All-in-one outdoor energy storage cabinets integrates energy storage battery PACK, battery management system(BMS), modular PCS, energy management system (EMS) , power distribution system, fire monitoring system, etc. The battery PACK is modular and the PCS modular design facilitates maintenance and capacity expansion. It has the advantages of small footprint, high integration , safety, reliability, low cost, high energy efficiency and intelligent management .

In common application scenarios, the operation strategy of the energy storage system is as follows:

Peak shaving and valley filling : When the time-of-use electricity price is in the valley section, the energy storage cabinet automatically charges and stands on standby after being fully charged; when the time-of-use electricity price is in the peak section, the energy storage cabinet automatically discharges; arbitrage of the electricity price difference is realized and the economic benefits of the optical storage and charging system are improved.

Solar energy-storage combination : Obtain local load power in real time, solar power generation is given priority for self-use, and excess power is stored. If solar power generation is insufficient to provide local loads, batteries are used first to store power.

The system is connected to the 0.4kV low-voltage power grid and mainly achieves the purpose of peak shaving and valley filling. Carry out regular charge and discharge control according to the peak and valley periods of the project. The charging and discharging control is carried out according to 2 charging and 2 discharging every day, that is, valley charging-peak discharging-flat charging-peak discharging.

2、standard

Standard	standard name
GB/T 36276-2018	Lithium-ion batteries for power energy storage
GB/T 34131-2017	Technical specifications for lithium-ion battery management systems for electrical chemical energy storage power stations
GB/T 34120-2017	Technical specifications for energy storage converters for electrical chemical energy storage systems
GB/T 34133-2017	Energy storage converter testing technical regulations
GB 51048-2014	Design specifications for electric chemical energy storage power stations
GB/T 36558-2018	General technical conditions for electric chemical energy storage systems in power systems
GB/T 36547-2018	Technical regulations for connecting electric chemical energy storage systems to the power grid
	Test specifications for electric chemical energy storage systems connected to the power grid
GB/T 36548-2018	Test specifications for electric chemical energy storage systems connected to the power grid
GB/T 32589-2017	Technical regulations for micro grid access to power systems
GB/T 10228-2015	Three-phase dry-type power transformer technical parameters and requirements
GB 4208-2017	Enclosure protection level (IP code)
GB/T 2423.4-2008	Environmental testing of electrical and electronic products Part 2: Test methods Test Db: alternating damp heat (12h + 12h cycle)
GB7251-2013 _	National standard for low-voltage complete switchgear
GB 50217-2007	Design specifications for power engineering cables
GB 17799.4-2012	Common standards for electromagnetic compatibility Emissions in industrial environments
GB 8702-88	Electromagnetic radiation protection regulations
GB 50150-2016	Standard for handover test of electrical equipment for electrical installation installation projects
GB/T 15945-2008	Power quality power system frequency deviation
GB/T 15543-2008	Power quality three-phase voltage imbalance
GB/T 14549-2008	Power Quality Utility Grid Harmonics
GB12325-2008	Power quality supply voltage allowable deviation
GB/T 12326-2008	Power Quality Voltage Fluctuation and Flicker
GB/ T191-2008	Packaging, storage and transportation diagram
DL/T 860-2016	Power enterprise automation communication network and system
DL/T 596-1996	Preventive testing procedures for electrical equipment

3、 System diagram

3.1. Topology diagram

The type of this project is energy storage peak shaving and valley filling, and the system is connected to the 0.4kV low-voltage power grid .

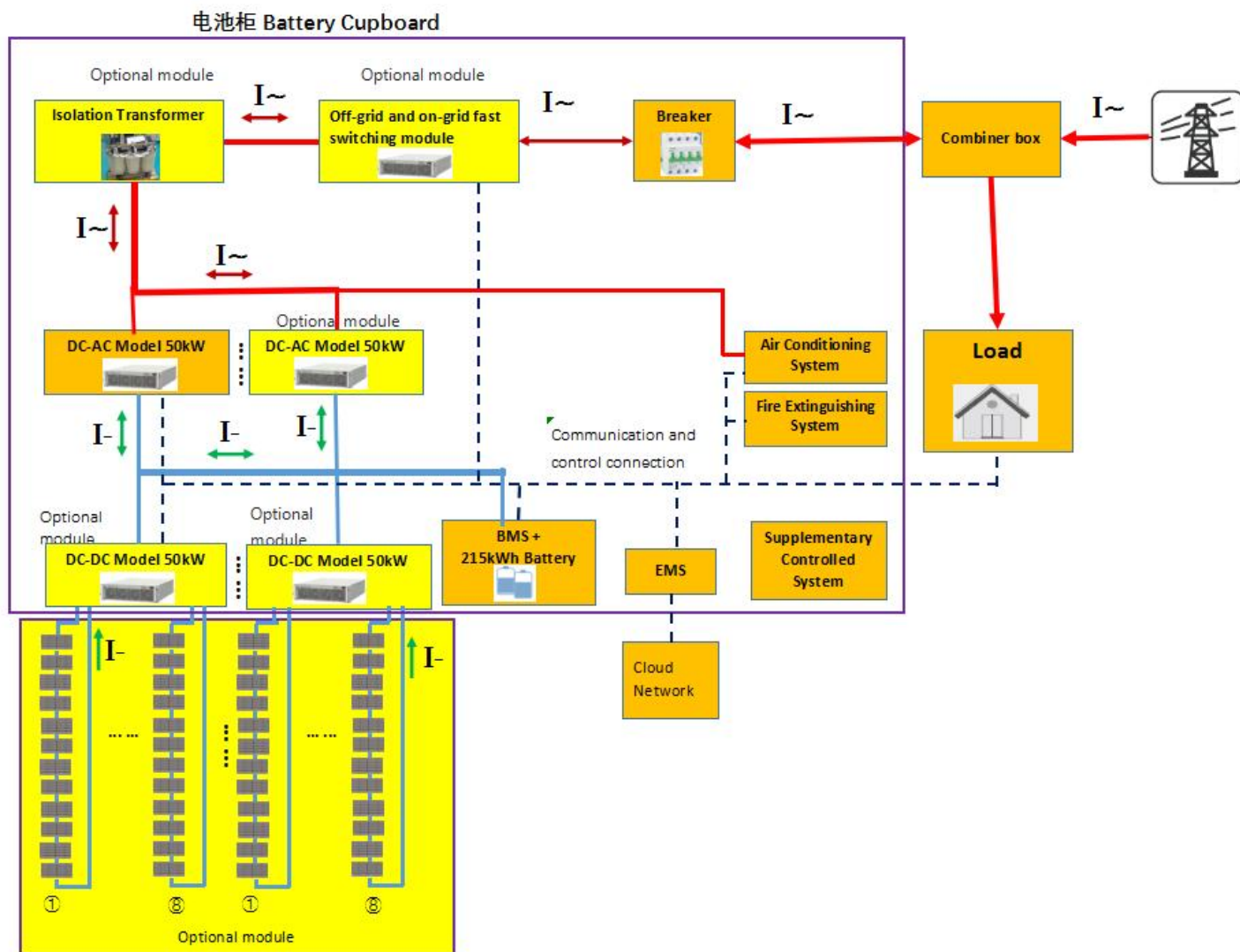

3.2. Diagram

This schematic diagram of the battery cabinet is for reference, and the specific shape and size are subject to the actual design.



3.3. Dimensional diagram

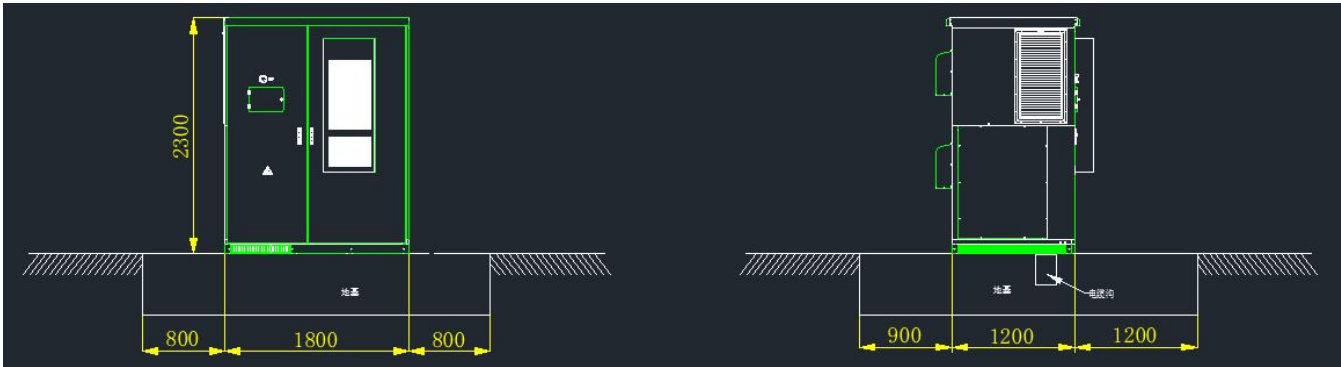

3.4. Product advantages

1) Integration Systematic Products, integrating energy storage batteries, power conversion module(pcs), power distribution systems,air conditioner, and fire extinguishing systems to fully control the system operating status and risks,EMS in one cabinet.

2) Configure the rack modular battery PACK and PCS, which supports parallel connection of multiple batteries and PCS and has good scalability. The number of PCS modules and total battery power can be selected according to the system capacity requirements of different scenarios. The typical configuration is: 100kw/215kwh.

3) Protection grade IP54, can be used directly outdoors and adapt to different types of weather.

4) The door-mounted embedded integrated air conditioner is used, which does not occupy cabinet space, increases the available space of outdoor cabinets, has better top structural integrity and better waterproof effect.

5) The local control panel can realize system operation monitoring, energy management policy limitation, remote equipment upgrade and other diversified functions.

6)This All-in-one cabinet is suitable for microgrid scenarios such as small-scale commercial and industrial energy storage, photovoltaic diesel storage, and photovoltaic storage and charging. The local control screen can perform a variety of functions, such as monitoring system operation, formulating energy management strategies, and upgrading remote equipment.

7)This microgrid management system utilizes a multi-energy complementary power supply mode with photovoltaic power generation supplemented by diesel engine/grid. It's ideal for areas without stable power supply such as islands and borders, as well as new energy photovoltaic self-consumption scenarios like green buildings and zero-carbon parks in urban areas.

4、 All-in-one cabinet technique

4.1. System cabinet parameters

Model	100kwh/50kw	215kwh/100kw
PV port		
Rated PV input power	50kw	100kW
Mppt quantity	2/4	4/8
PV voltage range	200 ~850V	200 ~850V
Grid / Diesel port		
Rated AC power	50kW	100kW
Max. power	55kVA	110kVA
Rated current	72A	144A
Max. current	79A	158A
Rated AC voltage	400V(-20%~ +15%),,3P+N+PE,50/60Hz	
THDi	<3%(rated power)	
PF	-1 leading to+1 lagging	
Battery energy storage port		
Battery material	Lithium iron phosphate battery (LFP)	
Rated battery capacity	100kwh	215kwh
Rated system voltage	844.8V	768V
Battery Cell capacity	120Ah	280Ah
Series of battery	1P*24S*12S	1P*20S*12S
Cycle Life	≥ 6000times,0.5C / 0.5C, 25 °C	
BMS structure	two levels, BMU and BCU.	
Load port		
Rated AC power	50kW	100kW
Overload capacity	110%,normaloperation;120%,1minute;	

Rated AC voltage	400V,3P+N+PE,50/60Hz	
THDi	<3%(linear load)	
PF	-1 leading to+1 lagging	
General Parameters		
Max efficiency	97.6%	
Protection level	IP54	
Isolation mode	Non-Isolation (Adding isolation transformer is optional)	
Operating temperature	-25~60℃(Derating above 45℃)	
Altitude	3000m(>3000m derating)	
Communication interface	RS485/CAN 2.0/ Ethernet/dry contact	
STS	STS optional	STS optional
Transformer	Transformer inside	Transformer inside
Dimension(W*D *H)	1200*1000*2150mm	1800*1200*2300mm
Weight (with battery)	1500kg	3000kg

4.2 Components Introduction

4.2.1 Battery energy storage system



Cell parameters		
Battery model	100kwh	215kwh
Cells Chemical	LFP	LFP
Rated Voltage	3.2V	3.2V
Working Voltage Range	2.8-3.6V	2.8-3.6V
Nominal Capacity	120Ah	280Ah
Working Temperature Range, Charge	0~+55 °C	0~+55 °C
Working Temperature Range, Discharge	-20~ +55 °C	-20~ +55 °C
Battery Pack		
Cell series and parallel connection qty	1P24S	1P20S
Rated Energy	9.216kWh	17.92kWh
Rated Voltage	76.8V	64V
Working Voltage Range	60-87.6V	56-72V
Weight	39±1kg	139±1kg
All-in-one cabinet battery capacity		
Battery Pack Quantity	11	12
Rated Energy	101kWh	215.04kWh
Rated Voltage	844.8V	768V
Working Voltage Range	660 ~ 963.6V	600 ~ 876V
Gross Weight	800kg	1680kg

4.2.2 Battery Management System(BMS)

The energy storage management system consists of the battery management system (BMS) and the energy management system(EMS). The battery selected by our company comes with its own BMS management system, which is divided into two levels, BMU and BCU.

The BMU is located in the battery box, completes the data collection of the individual cell information inside the battery box, and uploads the data to the BCU. At the same time, it completes the balancing of the individual cells in the battery box according to the instructions issued by the BCU.

The BCU is located in the main control box and is responsible for the management of the battery cabinet. It accepts detailed data uploaded by the BMU inside the battery, collects the voltage and current of the battery cabinet, performs SOC calculation and correction, is responsible for battery charge and discharge management, and transfers relevant data Upload to EMS.

project	Parameter	Remark
Working voltage range	9V/36V	For reference only, the actual range shall prevail.
BMS working power consumption	Rated power≤30W	
BMS static consumption	≤50μA	
BMS operating temperature range	-40℃~+85℃	
BMS storage temperature range	-40℃~+95℃	
BMS working humidity range	0~85%	
SOC estimation accuracy	≤8%	Pure electric working status
Cell voltage detection range	0~5V	
Cell voltage sampling accuracy	≤±10mV	2V~5V -20℃~55℃
Cell voltage sampling frequency	<100mS	
Total voltage detection accuracy	<0.5%FSR	FSR: full scale range
Temperature measurement range	-40~+120℃	
Temperature detection accuracy	<±1℃	
Current detection accuracy	<1%FSR	FSR: full scale range
Communication function	An RS232/RS485/CAN communication interface should be provided, and a corresponding communication protocol should be provided to upload the lithium battery to the monitoring platform in real time.	

Function	Module high voltage alarm, module low voltage alarm, discharge over current alarm, charging over current alarm, discharge battery high temperature, rechargeable battery high temperature, discharge battery low temperature, rechargeable battery low temperature, charging system high voltage, discharge system low voltage
----------	--

1) Single battery voltage detection

It adopts a special voltage measurement chip and contains a high-precision A/D conversion module. Accurately and timely monitor battery status and changes during use. Effectively prevent improper use of batteries.

2) Battery temperature detection

Using digital temperature measurement chip, it has good scalability and high detection accuracy.

3) Battery pack operating current detection

It adopts full-scale, high-precision sensors and high-precision integrated chips to meet the needs of current detection and energy accumulation.

4) Battery SOC estimation

Through the current sampling of the shunt, current measurement and SOC estimation are completed, and based on the control parameter requirements, fault classification alarms are performed for excessively high or low SOC.

5) Battery discharge capacity accumulation

In charging mode, the battery management master can record the cumulative charge and discharge capacity of the battery pack.

6) Battery failure analysis and online alarm

BMS has system self-diagnosis function. After the system is powered on, it detects voltage, temperature, communication, clock, memory, internal communication, etc. At the same time, it can judge and alarm the over voltage, under voltage, over current and over temperature of the battery. Consistency of SOC too low/high and battery failure.

7) Charging management

Based on the current information of the battery, the BMS provides the charger with the maximum charging current allowed by the battery in real time. The actual charging current of the battery should be the smaller value between the charging current allowed by the BMS and the maximum output current of the charger.

4.2.3 Electrical system

project	skills requirement	Remark
enter		
AC wiring	3P3W+PE	
AC voltage range	400±10%Vac; rated: 400Vac	3P3W+PE
frequency adaptability	Range: 45Hz~65Hz; Rating: 50/60Hz	
Static withstand voltage	Can withstand 1100V input high voltage impact without damaging the module	Allow the module to enter the protected state.
power factor	-1~+1	Adjustable
THDI	≤3%	
Protective function		

Over current protection	All three AC phases are protected by fuses	
Over voltage protection	Protection point: 440±5V	Any one of the three phases will automatically recover
Over voltage recovery	Can automatically recover, the return difference is not less than 10V.	
Under voltage protection point	Protection point: 360±5V	Any one of the three phases will automatically recover
Under voltage recovery point	The return difference is not less than 15V	
Over temperature protection	Has over temperature protection	Long-term overheating will not damage the machine
DC side		
DC voltage range	600Vdc~1000Vdc	
Rated output power	100kW	
Rated DC current	166.7A	
Switching machine overshoot amplitude	≤±5%	Full voltage input range, full load output
Charge and discharge switching time	≤20ms	-100%~+100% switching
efficiency	≥98.5%	Rated output voltage, 100% load current test
Voltage stabilization accuracy	≤±1%	
Steady flow accuracy	≤±1%	At 20%~100% rated current
Current imbalance	≤5%	More than 20% of rated current (system tested)
Protection characteristics		
DC over voltage protection	1000Vdc±5Vdc	Can be set
AC short circuit protection	Short circuit is not damaged and needs to be restored manually.	
Battery reverse polarity protection		Reverse battery connection will not cause personal safety hazards

4.2.4 Energy Storage Converter Power Module (PCS)



This series of outdoor cabinet energy storage systems adopts a modular solution. Users can configure different numbers of power modules according to project requirements.

DC/AC module: offers multiple operating modes such as PQ, VF, VSG, CV, MPPT; Three-level topology ensures high conversion efficiency and compatibility with 3-phase 3/4-wire outputs.

DC/DC module: combines solar charging and energy storage functions, with high efficiency and low ripple current thanks to dual interleaved parallel control.

Product Features:

Flexible and convenient: standard rack-mounted modular design with flexible configuration, maintenance, and expansion.

Diversified functions: supports various types of energy storage batteries and photovoltaic modules, auto-identifies devices.

DC/ AC system is adaptive to three-phase three-wire/ four-wire and voltage phase sequences, offering more flexible applications.

DC/ DC DC/ DC system with two inputs enables multi-channel MPPT and battery management with advanced interleaved control technology, small ripple current, and extended battery life.

DC/ DC and DC/ AC adopt three-level circuit design, high conversion efficiency.

Product Model	PCS-50DC-AC	Remark
Rated power	50kw	2sets*50KW/ module
Rated power	55kW	
DC working voltage range	500-900V	
DC full load working voltage range	500-900V	
Max DC current	110 A	
Rated AC voltage	400Vac,3W+PE	
Rated grid frequency	50Hz	
Rated AC Current	72A	
Overload capacity	110%,normal working 120%, 1 minutes	
Power factor adjustable range	-0.1 (lead) ~+ 0.1 (lag)	
Reactive power response time	≤ 30ms	
Power control accuracy	≤ 5%	
Adapted DC power	Lead acid battery,Li-ion battery,solar panels	
Charge mode	BMS signal,mppt	
Working mode	Constant current,constant power,mppt,AC Power,DC power,VSG	
Max efficiency	98.2%	
Noise	< 70 dB	
Cooling method	Air conditioner cooling	
Communication	CAN or RS485	
Working temperature	-25 °C ~ + 60 °C	> 45 °C derating
Storage environment	-20 °C ~ + 70 °C	

Product Model	PCS-50DC-AC	Remark
temperature		
Relative humidity	0 ~ 95% , no condensation.	
Isolation way	Non-isolation	
Size(W*D*H)	483*600*150mm	
Weight	35kg	

For islands, mountainous areas, border checkpoints, and other remote areas or areas with unstable power supply, or for the construction of light storage systems in zero carbon technology parks. Users can configure DC converter power modules according to project requirements to achieve an integrated photovoltaic and energy storage power supply system. The parameters of the DC converter power module are as follows:

Product Model	PCS-50DC-DC	Remark
Rated power	50kw	
Rated power	55kW	
DC working voltage range	200-1000V	
Low-voltage side ,full load working voltage range	312-850V	
Low-voltage side ,Max DC current	80 A*2	
Low-voltage side,input ports	2	2 ports can be combined to be 1port
High-voltage side ,full load working voltage range	500-900V	
High-voltage side ,Max DC current	110A	
High-voltage side,input ports	1	
Adapted DC power	Lead acid battery,Li-ion battery,solar panels	
Working mode	Constant current,constant voltage,constant power,mppt	

Product Model	PCS-50DC-DC	Remark
Max efficiency	98.8%	
Noise	< 70 dB	
Cooling method	Air conditioner cooling	
Communication	CAN or RS485	
Working temperature	-25 °C ~ + 60 °C	> 45 °C derating
Storage environment temperature	-20 °C ~ + 70 °C	
Relative humidity	0 ~ 95% , no condensation.	
Isolation way	Non-isolation	
Size(W*D*H)	440*600*150mm	
Weight	25kg	

4.2.5 Temperature control system

Considering the operating environment of the battery system, in order to ensure long-term reliable operation of the battery, the battery compartment should be equipped with a temperature control system, including a heating system and a ventilation system, and ventilation and heating ducts should be designed to ensure uniform temperature inside the box (25 ± 5 °C) .

The energy storage outdoor cabinet uses an integrated industrial air conditioner. A temperature sensor is installed in the container, and the temperature sensor sends the temperature signal to the local control system (HMI).

4.2.6 Fire protection system

The aerosol fire extinguishing device used in the fire protection system is a new environmentally friendly fire protection product with the world's advanced level. Working principle: When the ambient temperature reaches the starting temperature of the thermal line or comes into contact with an open flame, the thermal line

will spontaneously ignite and be transferred to the aerosol series fire extinguishing device. After the aerosol fire extinguishing device receives the start signal, the fire extinguishing agent inside is activated, and the nano-type aerosol fire extinguishing agent is quickly generated and sprayed out to achieve rapid fire extinguishing.

The battery compartment is equipped with smoke detectors and water immersion sensors, and the signals are uploaded to the HMI.

4.2.7 Monitoring system



project	requirement	Remark
Testing requirements		
AC voltage detection	Detection extreme value: 584Vac; accuracy $\pm 1\%$	
DC voltage detection	Detection range: 200Vdc~1000Vdc; detection accuracy $\pm 1\%$	
Current Detection	Detection range: 0A~200A; detection accuracy $\pm 1\%A$	
Current limit detection	Detection range: 0A~300A; detection accuracy $\pm 1\%A$	
Display function	none	
Indicator light definition	The red and green light-emitting diodes can respectively display the fault, alarm and running status of the power supply.	
Alarm function		
Module fault alarm	When the module fails to operate due to module failure, such as over voltage, over temperature, failure to operate due to internal module faults, etc., the module issues a fault alarm. When an alarm occurs, the red indicator light of the module flashes; this alarm can be reported to the host computer through the communication port.	
Fan failure alarm	When the fan fails or is blocked, a fan failure alarm is generated and the red light flashes. Alarms can be reported to the host computer through the CAN bus. The alarm is cleared after the fault is rectified.	

	This alarm can be reported through the communication port.	
Mains power under voltage alarm	When the mains voltage is lower than 360Vac, the red light flashes; when the mains voltage is higher than 365Vac, the alarm is cleared. This alarm can be reported through the communication port.	
Mains over voltage alarm	When the mains voltage is higher than 440Vac, a mains over voltage alarm occurs and the yellow light flashes; when the mains voltage is lower than 430Vac, the alarm is cleared. This alarm can be reported through the communication port.	
Monitoring interface		
Communication Interface	Provide RS485 for host computer communication and CAN communication for module parallel communication.	
Parallel communication function requirements	Configuration parameter synchronization parameter arbitration: AC/DC voltage: When there are differences in the modules of the parallel machine, the HMI can display the parameters of each module separately. Load current: reported separately by different modules. Alarm: Module failure and fan failure are reported separately. Public alarms are reported together. Status: Merged and reported.	
Parallel capability	Can support 10 modules working in parallel.	Can support up to 256 modules working in parallel
software upgrade	The module supports software upgrade function and can be loaded online through the monitoring interface.	During the upgrade process, load power loss is not allowed. Allow the conversion section to pause work.

5、 Safety, EMC and lightning protection characteristics

serial number	project	Standard (or test condition)	Remark	
1	anti-electricity powerful Spend	input versus output	non-isolated	No flash over, no breakdown Leakage current <10mA
		Input to PE	2121Vdc/1min	
		Output and PE	2121Vdc/1min	
		Input and output pair RS485	4242Vdc/1min	
2	Absolutely edge electricity block	input versus output	no request	
		Input to PE	≥1MΩ@1000Vdc	
		Output and PE	≥1MΩ@1000Vdc	
3	Leakage current to earth	<10mA to ground		
4	Safety certification	The design complies with the EN60950 standard and the product finally passed CE certification.	Safety certification altitude: 2000m	
5	Lightning protection	AC port lightning protection: 10kA	8/20us impulse current wave, impulse current criterion B	
6	Surge immunity SURGE	Input surge: Line to line: 1kV, 2Ω; Line to ground: 2kV, 12Ω; Positive to negative: 500V, 40Ω; Positive and negative to ground: 1kV, 40Ω;	1.2/50-8/20us mixed wave, plus and minus 5 times each, with an interval of 1 minute each time; level 3, criterion A; GB-T17626.5 (IEC61000-4-5)	
		Output load port: 800V		
7	Radiated emission limit RE	CLASS A;	(IEC61000-6-4)	
8	Conducted emission limits CE	CLASS A;	(IEC61000-6-4)	
9	Conducted disturbance immunity CS induced by RF fields	10Vrms/m Level 3, Criterion A	(IEC61000-6-2)	
10	Radio frequency electromagnetic field radiation immunity RS	10Vrms/m level 3, criterion A	(IEC61000-6-2)	
11	Voltage dips and short interruptions AC-DIP	100% dip for 20ms 60% dip for 500ms 30% dip for 500ms 100% dip for 5000ms	GB-T17626.11 (IEC61000-4-11) 20ms test with half load	

		The criteria are B, B, C, and C respectively;	
12	Fluctuations and Flicker		EN61000-3-3
13	Electrostatic discharge immunity ESD (casing, power port)	Shell, parts that can be touched by hands during normal operation: contact discharge $\pm 4\text{kV}$; air discharge $\pm 8\text{kV}$ Level 3, criterion B; (power on during test)	GB-T17626.2 (IEC61000-4-2)
14	Electrostatic discharge immunity ESD (signal port)	Conductor within the signal interface: contact discharge: 2kV ; Criterion R	GB-T17626.2 (IEC61000-4-2)
15	Electrical Fast Transient Burst Immunity EFT	AC: $\pm 2\text{kV}$, 120s; DC: $\pm 1\text{kV}$, 120s; Level 3 Criterion B	GB-T17626.4 (IEC61000-4-4)
16	Oscillatory wave immunity	Level 3 Criterion B	GB-T 17626.12& (IEC 61000-4-12)
17	Power frequency magnetic field immunity	10A/m level 3, criterion A	GB-T 17626.8& (IEC 61000-4-8)
18	Pulsed magnetic field immunity	300A/m level 4, criterion A	GB-T 17626.9& (IEC 61000-4-9)
19	Damped oscillating magnetic field immunity	10A/m level 3, criterion A	GB-T17626.10 (IEC61000-4-10)
20	Rohs _	Comply with Rohs R5	
21	<p>Criterion A: During the test process, the performance of the equipment is not allowed to change within the technical requirements, and the voltage fluctuation is within the voltage stabilization accuracy range.</p> <p>Criterion B: During the test process, the performance degradation of the equipment is allowed within the range required by the product specification (not exceeding the output voltage range). After the interference is eliminated, the equipment can return to normal. Reset and any form of manual intervention are not allowed. Voltage is allowed. Glitch with fluctuation range within 200us.</p> <p>Criterion C: Temporary loss of functionality is allowed, but can be restored by itself or through running control operations, or for switching equipment, the connection can be reestablished through normal control operations.</p> <p>Criterion R: Damage to any device other than the protection device is not allowed, and the performance of the test piece can be restored after replacing the damaged protection device.</p> <p>Criterion for impulse current: The equipment is tested under live working condition, and the service is monitored before and after the test. During the test, only optical fiber is allowed to detect the service. During the test, bit errors, temporary link interruption, and signal loss are</p>		

allowed. Power outages, device damage, service interruptions that cannot be restored after the test, and permanent performance degradation are not allowed during the test.

6、 Environmental and Reliability Test Requirements

Project	skills requirement	Remark
Application Environment		
Use	<ul style="list-style-type: none"> ■ Continuous operation in an indoor air-conditioned environment. ■ Continuous operation in indoor non-air-conditioned environment. ■ Continuous operation in an environment with simple weather protection. <input type="checkbox"/> Continuous operation outdoors <input type="checkbox"/> No fixed working environment. ■ Operate in a small space with high temperature. <input type="checkbox"/> Installed on vibrating devices or cars. <input type="checkbox"/> Used in mines. <input type="checkbox"/> Others (need detailed description) 	
Transportation	<ul style="list-style-type: none"> ■ Land transportation ■ Water transport ■ Air transport <input type="checkbox"/> Manual handling <input type="checkbox"/> Others (details required) 	
Storage	<ul style="list-style-type: none"> ■ Limit storage environment temperature and humidity ■ Limit ambient temperature to keep dry ■ No temperature limit but temperature must be controlled ■ Simple protection from weather and rain erosion environment <input type="checkbox"/> Environment without wind and rain protection measures <input type="checkbox"/> Others (details required) 	
Note: Please select the actual working environment to change " <input type="checkbox"/>		
Reliability test		
Low temperature working test	GB2423.1 Method Ad	

High temperature working test	GB2423.2 Method Bd	
Low temperature storage test	GB2423.1 Method Ab	
High temperature storage test	GB2423.2 Method Bb	
High and low temperature cycle test	GB/T 2423.22	
constant heat and humidity experiment	GB/T2423.3 Method Cab	
Low pressure test	GB/T 2423.21	
random vibration experiment	ETSI EN3000 019-2-2 T2.3	
Sinusoidal vibration experiment	GR-63-CORE 5.3.2	
Drop test	GR-63-CORE 5.3.1	
MTBF	>100,000h (at 25°C)	
Power supply repair rate	Annual repair rate of power board: ≤1%;	
Working temperature: -40°C to +65°C. -40°C~+45°C Full performance operation. +45°C~+65°C derated operation. Storage temperature: -40°C to +75°C.		

7、Photovoltaic (optional)

A single DC / DC photovoltaic charging module is a two-channel MPPT, supporting a maximum photovoltaic input of 50 kW. Taking a 560 Wp monocrystalline photovoltaic solar panel as an example, the lower limit of the bus voltage is 672 V. The panel's open circuit voltage is calculated based on the high and low voltage difference of 30 V. Taking into account the negative temperature coefficient in winter, the panel's open circuit voltage does not exceed 610 V. It supports a maximum of 96 photovoltaic panels and uses 2 * 4P12S for string connection. The maximum photovoltaic panels access of a single DC / DC module reaches 52.8 kW .

Photovoltaic module performance parameter table

Photovoltaic Module(Solar Panel)	Monocrystalline silicon 560Wp	unit
Power	560	wp
Power Tolerance	0~+3	%
Operating Voltage	41.09	Vmp
Working Current	13.63	Imp
Open Circuit Voltage	49.82	Voc

Photovoltaic Module(Solar Panel)	Monocrystalline silicon 560Wp	unit
Short Circuit Current	14.21	Isc
Operating Temperature	-40~+85	°C
Maximum System Voltage	1000	VDC
Dimensions	2278 x 1134 x 35	mm
Weight	28	kg
Current Temperature Coefficient	+0.048	%/°C
Voltage Temperature Coefficient	-0.28	%/°C
Maximum Wind Load	2400	Pa
Maximum Snow Load	5400	Pa

8、 Main configuration list

No	Item	Specifications	Grid-connected type	Off-grid	Ongrid and off-grid switching	Remark
1	Inverter module(AC-AC)	AC 50kW, AC400V	√	√	√	
2	DC conversion power module(DC-DC)	DC 50kW	√	√	√	Combine with Photovoltaic solar panels (optional)
3	Parallel and off-grid switching module	STS, switching time <20mS,	×	×	√	
4	Main control board LED display	Soalr,battery data show	√	√	√	
5	Technical services and platforms	User manual	√	√	√	
6	Isolation transformer	SG- 100kVA 0.4kV/0.4kV Dyn11 (all copper)	×	×	√	
7	Battery	100kwh or 215kwh		1	set	

	capacity				
8	High voltage control box	Built-in BMS main control box, DC power supply, shunt, fuse, connector, etc.	1	set	
9	Air conditioner	3kw cooling capacity	1	set	
10	Fire extinguisher	QRRO.33GW/S	1	Pcs	
11	EMS system	Mobile platform	1	set	

9、Packaging, transportation and storage

9.1. Packaging

The packaging box contains the product name, model, manufacturer's logo, inspection certificate from the manufacturer's quality department, manufacturing date, etc.; the packaging box contains product specifications and a list of accessories.

9.2. Transportation

It is suitable for transportation by vehicles, ships and airplanes. During transportation, it should be covered, protected from the sun, and loaded and unloaded in a civilized manner.

9.3. Storage

The product should be stored in the packaging box when not in use. The ambient temperature of the warehouse is $-40\text{--}+75^{\circ}\text{C}$, and the relative humidity is 5%-95%. Harmful gases, flammable, explosive and corrosive products are not allowed in the warehouse. Chemical products without strong mechanical vibration, impact or strong magnetic field. The packaging box should be at least 20cm high from the ground and at least 50cm away from walls, heat sources, windows or air inlets. The storage period under these specified conditions is generally 2 years, and should be re-inspected after more than 2 years.

10、revision

The company has the right to revise this product proposal. If there is a need to revise the product proposal, please communicate with the company.